



DIN PN 16 - 250 bar — ND 15 x 25, 20 x 25, 25 x 25 and 25 x 40 mm  
 ANSI 150 - 1500 — 1/2" x 1", 3/4" x 1", 1" x 1" and 1" x 1 1/2"

**Application**

The ASCA HC safety and relief valves are used to protect industrial equipment and facilities against overpressure from air, water, steam, gases, viscous fluids and chemicals in general. Indicated for a wide range of pressure, they are employed in chemical and petrochemical industries, steam generation and distribution systems, heating or cooling systems among others.

**Presentation**

The HC valves are of angular construction and basically composed of body/integral nozzle (5) incorporating the seat, output nozzle (1) and castle (3). The body/nozzle (5) is always in stainless steel. The HC valves are supplied with closed castle (3) and cowl (4).

**Operation**

The HC safety and relief valves are automatic pressure relief devices, actuated by static pressure at the inlet, characterized by an instantaneous opening when operating with gases or steam and by a proportional opening when operating with liquids. The overpressures for gases or steam and for liquids are 10% of the opening pressure. The valves can be equipped with manual opening for testing.

**Ask for our sizing software**

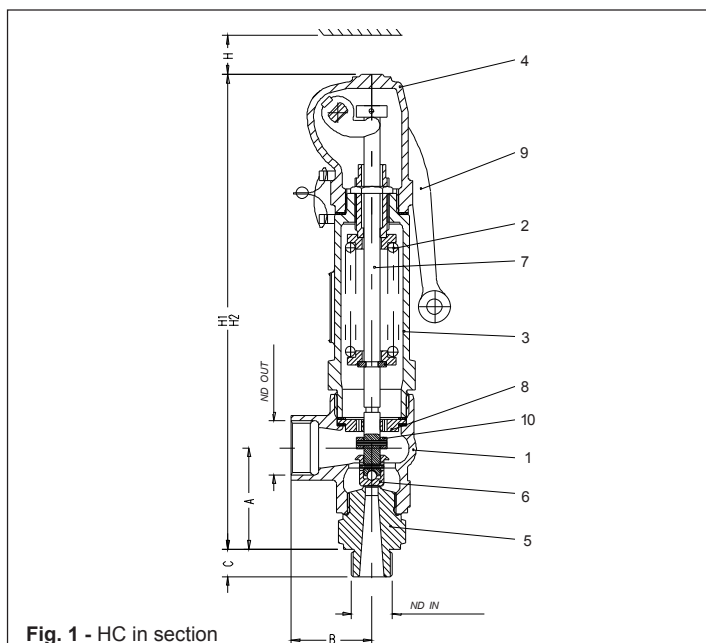

Fig. 1 - HC in section

Part	Designation	Qty.	Part	Designation	Qty
1	Exit nozzle	1	6	Stopper	1
2	Spring	1	7	Rod	1
3	Closed castle	1	8	Rod guide	1
4	Closed cap	1	9	Lever	1
5	Body / Nozzle	1	10	Course limiter	1

**Technical Competence, Material and Connections**

Models	HC 63	HC 64	HC 73	HC 74
Nominal pressure	DIN PN 160 - ANSI 900		DIN PN 250 - ANSI 1500	
Nominal diameter (mm)	1" x 1 1/2"		1/2" x 1" *; 3/4" x 1"; 1" x 1"	
d <sub>o</sub> - Orifice diam. (mm)	16		8	12,5
A <sub>o</sub> - Orifice area ( pol ) <sup>2</sup>	0.31		0.078	0.19
Max. open pressure.(bar)	68		150 (d <sub>o</sub> =8)	110(d <sub>o</sub> =12,5)

\* The 1/2" x 1" diameter is only available in = 8 mm (area 0,078 pol)<sup>2</sup>

**Materials & Connections**

Models	HC 63, 73	HC 64, 74
Body / Inlet nozzle / Seat	AISI 316	AISI 316
Outlet nozzle	ASTM A 216 WCB	ASTM A 351 CF8
Spring	N - Carbon Steel B - Stainless steel	— AISI 302
Castle Cap	closed	ASTM A 351 CF 8
Stopper / Rod / Rod guide	AISI 420	AISI 316
Lever	ASTM A 395	
<b>Optionals</b>		
Flanges	SAE 1020	AISI 316
Threaded connections	ISO R7 (BSP) ou ANSI / ASME B1.20.1 (NPT)	
Flanged connections	ANSI B 16.5 150 x 150 Lbs RF ou 300 x 150 Lbs RF	

### Recommended Spare Parts

Considered recommended spare parts for two-year operation are, the body/castle joint, the cowl/castle joint, the elastic pins, the ball, the body/seat and the shutter.

The recommended spare parts vary according to product application.

### Optional

- Flanged connections according to ANSI 16.5 classes 150 and 300 (fig. 2), with fitting flange at valve inlet, making its installation and maintenance easier. Other connections under consultation.

- Closed cowl without lever for process in which manual opening must be avoided or is unnecessary (mainly for liquid fluids) (fig. 4).

### Measures and weights

Input ND x output ND	mm	15x25; 20 x 25; 25 x 25 1/2" x 1" *; 3/4" x 1"; 1" x 1"	25 x 40 1" x 1.1/2"
d <sub>o</sub> - Orifice diameter	mm	8 or 12,5	16
Orifice Area	pol <sup>2</sup>	0,078 or 0,19	0,31
<b>Measures in mm (fig.1)</b>			
H - for assembly		150	150
H <sub>1</sub> - cowl without lever		270	285
H <sub>2</sub> - cowl with lever		265	280
A - center face input		63	65
B - center face output		50	60
C - length of thread		18	18
<b>Optional - with flanges (fig. 2)</b>			
D - ANSI classes 150 and 300	mm	133	138
E - ANSI classes 150 and 300	mm	123	143
Approximate weight in kg Without optional equip.		2	3

\* 1/2" x 1" diameter only available in do = 8 mm (area 0.078 in<sup>2</sup>)

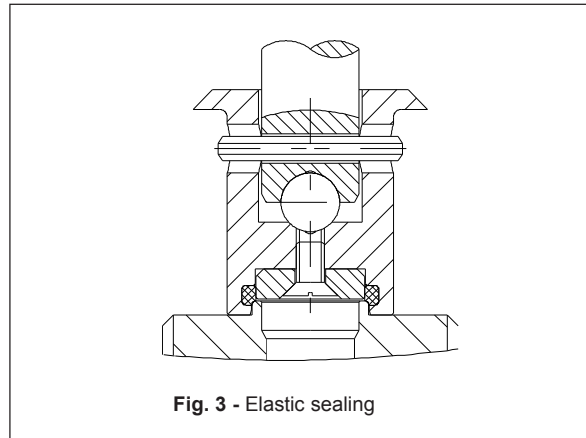
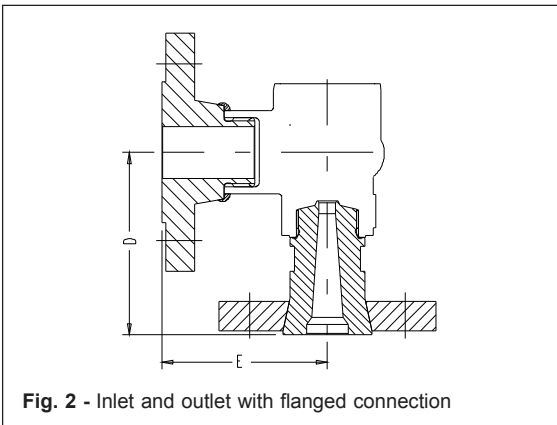

- Elastic seal in NEOPRENE (-45 to 100°C), VITON (-25 to 180°C), EPDM (-60 to 150°C) and Kalrez (under consultation) (fig. 3).

- Elastomer bellows in EPDM to protect against corrosive fluids and incrustation and/or for sealing toxic fluids, chemicals or food products and others (fig. 5).

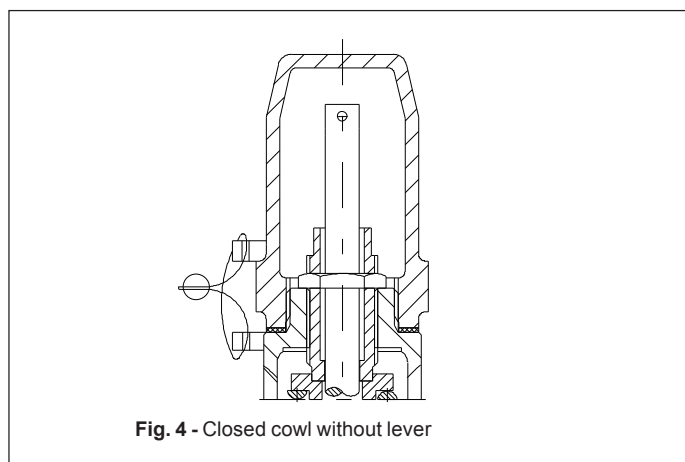

**Saturated steam flow capacity in Kg/h**

ND (mm)	15x25*; 20 x 25; 25x25		25 x 40	DN (mm)	15x25*; 20 x 25; 25x25		25 x 40
d <sub>o</sub> (mm)	8	12,5	16	d <sub>o</sub> (mm)	8	12,5	16
p (bar)				p (bar)			
0,5	—	61	99	34	705	1723	2823
0,75	—	77	127	36	746	1821	2984
1	—	93	153	38	785	1918	3142
1,5	50	123	201	40	826	2018	3306
2	62	152	249	42	867	2118	3471
3	85	206	338	44	907	2218	3638
4	105	257	422	46	948	2318	3790
5	126	307	504	48	989	2415	3957
6	146	357	585	50	1028	2510	4113
7	166	406	666	52	1068	2609	4275
8	186	456	747	54	1120	2735	4481
9	207	505	828	56	1141	2785	4564
10	227	554	909	58	1194	2916	4777
12	267	653	1070	60	1234	3013	4936
14	307	750	1229	62	1276	3116	5105
16	347	848	1389	64	1318	3219	5275
18	387	945	1549	66	1367	3337	5468
20	427	1043	1708	68	1406	3433	5625
22	466	1139	1866	70	1445	3528	
24	506	1237	2027	72	1487	3632	
26	547	1336	2189	74	1529	3733	
28	586	1432	2347	76	1574	3844	
30	626	1529	2506	78	1625	3968	
32	667	1628	2668	80	1654	4039	

\* (The 1/2" x 1" diameter is only available in = 8 mm (area 0,078 inch)

**- Water flow capacity in tons/hour (t/h) at 20°C.**

- For liquids different from water at 20°C ( ρ =998 Kg/m³), multiply the liquid flow by factor F =

$$\sqrt{\frac{\rho_{\text{agua}}}{\rho_{\text{liquido}}}}$$

checking the table below to obtain the ND of the valve.

ND (mm)	15x25*; 20 x 25; 25x25		25 x 40	ND (mm)	15x25*; 20 x 25; 25x25		25 x 40
d <sub>o</sub> (mm)	12,5		16	d <sub>o</sub> (mm)	12,5		16
p (bar)				p (bar)			
0,5	2,6		4,3	40	23,6		38,8
0,75	3,2		5,3	42	24,2		39,7
1	3,7		6,1	44	24,8		40,7
1,5	4,5		7,5	46	25,4		41,6
2	5,2		8,6	48	25,9		42,5
3	6,4		10,6	50	26,4		43,3
4	7,4		12,2	52	27,0		44,2
5	8,3		13,7	54	27,5		45,0
6	9,1		15,0	56	28,0		45,9
7	9,9		16,2	58	28,5		46,7
8	10,5		17,3	60	29,0		47,5
9	11,2		18,4	62	29,4		48,3
10	11,8		19,4	64	29,9		49,0
12	12,9		21,2	66	30,4		49,8
14	14,0		22,9	68	30,8		50,5
16	14,9		24,5	70	31,3		
18	15,8		26,0	72	31,7		
20	16,7		27,4	74	32,2		
22	17,5		28,7	76	32,6		
24	18,3		30,0	78	33,0		
26	19,0		31,2	80	33,4		
28	19,8		32,4	85	34,5		
30	20,5		33,6	90	35,5		
32	21,1		34,7	95	36,5		
34	21,8		35,7	100	37,4		
36	22,4		36,8	105	38,3		
38	23,0		37,8	110	39,2		

\* (The 1/2" x 1" diameter is only available in = 8 mm (area 0,078 inch), flowrate not acc. to the table.

**Flow capacity and air in normal cubic meters per hour (Nm<sup>3</sup>/h) at 0°C and 1013.25 mbar absolute**

ND (mm)	15 x 25*	20 x 25	25 x 25	25 x 40	ND (mm)	15 x 25*	20 x 25	25 x 25	25 x 40
d <sub>s</sub> (mm)	8	12,5	16	20	d <sub>s</sub> (mm)	8	12,5	16	20
p (bar)					p (bar)				
0,5	—	72	118	157	58	1626	3970	6505	8505
0,75	—	96	157	209	60	1681	4105	6725	8725
1	—	117	192	263	62	1736	4239	6946	8946
1,5	63	155	253	343	64	1791	4374	7166	9166
2	79	193	316	417	66	1846	4508	7387	9387
3	108	264	433	577	68	1901	4643	7607	9607
4	137	336	551	742	70	1957	4778	7827	9827
5	165	403	661	912	72	2012	4912	8047	10047
6	192	471	771	1087	74	2067	5047	8267	10267
7	220	538	882	1267	76	2122	5181	8487	10487
8	248	605	992	1452	78	2177	5316	8707	10707
9	275	672	1102	1642	80	2232	5450	8927	10927
10	303	740	1212	1837	85	2370	5787	9427	11427
12	358	874	1433	2187	90	2508	6123	9927	11927
14	413	1009	1653	2537	95	2646	6460	10427	12427
16	468	1144	1874	2887	100	2784	6796	10927	12927
18	523	1278	2094	3237	105	2921	7133	11427	13427
20	578	1413	2315	3587	110	3059	7469	11927	13927
22	633	1547	2535	3937	115	3197	7806	12427	14427
24	689	1682	2756	4287	120	3335	8142	12927	14927
26	744	1816	2976	4637	125	3473	8478	13427	15427
28	799	1951	3197	4987	130	3610	8814	13927	15927
30	854	2086	3417	5337	135	3748	9150	14427	16427
32	909	2220	3638	5687	140	3886	9486	14927	16927
34	964	2355	3859	6037	145	4024	9822	15427	17427
36	1019	2489	4079	6387	150	4162	10158	15927	17927
38	1075	2624	4300	6737	160	4437	10794	16427	18427
40	1130	2759	4520	7087	170	4713	11430	16927	18927
42	1185	2893	4741	7437	180	4989	12066	17427	19427
44	1240	3028	4961	7787	190	5264	12702	17927	19927
46	1295	3162	5182	8137	200	5540	13338	18427	20427
48	1350	3297	5402	8487	210	5816	13974	18927	20927
50	1405	3432	5623	8837	220	6091	14610	19427	21427
52	1460	3566	5843	9187	230	6367	15246	19927	21927
54	1516	3701	6064	9537	240	6643	15882	20427	22427
56	1571	3835	6284	9887	250	6918	16518	20927	22927

For gases other than air not present on the below chart, use the following formula:

$$f = \frac{0,09\sqrt{M}}{\psi}$$

where:

M = molecular mass

ψ = gas or vapor flow coefficient

(fig. 1 from IT 0901 P)

\* 1/2" x 1" diameter only available in do = 8 mm (area 0.078 in<sup>2</sup>)

**For gases other than compressed air, multiply the gas flow by the factors below, then go into the flow table below to determine the valve's ND.**

Gas	Formula	Factor	Gas	Formula	Factor
Acetylene	C <sub>2</sub> H <sub>2</sub>	0,98	Hydrogen	H <sub>2</sub>	0,26
Ammonia	NH <sub>3</sub>	0,78	Methane	CH <sub>4</sub>	0,76
Butane	C <sub>4</sub> H <sub>10</sub>	1,54	Carbon monoxide	CO	0,98
Carbon Dioxide	CO <sub>2</sub>	1,27	Nitrogen	N <sub>2</sub>	0,98
Ethane	C <sub>2</sub> H <sub>6</sub>	1,08	Oxygen	O <sub>2</sub>	1,05
Ethylene	C <sub>2</sub> H <sub>4</sub>	1,02	Propane	C <sub>3</sub> H <sub>8</sub>	1,32

**Orders**

Indicate the opening pressure, backpressure, variable or not, the fluid, its temperature, flow and viscosity, standard and type of connection, type of castle and cowl, body material, type of seal and standards to be complied with.

**Standardized specification**

Safety and relief valve  
 model HC.....from ASCA  
 Conforming PR-09.10.11-I brochure  
 Opening Pressure.....  
 Connections.....  
 Conforming standard.....  
 Nominal diameter.....  
 Optional.....  
 Special execution.....

**ASCA EQUIPAMENTOS INDUSTRIAIS LTDA.**

R. Fernandes da Cunha, 202- Vigário Geral - Rio de Janeiro - RJ - Brazil  
 CEP 21241-300 - Tel.: (21) 2472-6900 - Fax (21) 3014-7622  
 e-mail: office@asca.com.br - homepage: http://www.asca.com.br

SPECIFICATIONS SUBJECT TO CHANGE WITHOUT NOTICE.

Ask for certified print for exact dimensions