

DIN PN 10- 40 bar — ND 15 - 600mm
 ANSI 125 - 300 — 1/2" - 24"

FS 11, FS 13, FS 33

Application

To eliminate suspended condensate or droplets, as well as other contaminants, in steam, compressed air or other gas installations. Applied to land and maritime facilities as well (See Technical Information 1101 – Greater yield and safety for steam and compressed air networks).

Main Characteristics

- Two fuse helicoid body producing centrifugal forces, which increases the effect of separation of condensates and contaminants from the fluid.
- Sudden 180° direction inversion substantially reinforces this effect.
- Conic deflector hinders upward dragging of condensate and contaminants separated from the fluid.
- No maintenance needs due to the absence of moving parts.
- Flow in both directions.
- Minimum head loss.
- Long operation life.

Construction

The FS centrifugal separators have no moving parts. They consist, basically, of body, heads, and helicoid centrifugator with conic deflector. Provided with straight pass (fig. 1). Models FS 13 and FS 33 may also be provided with angular construction, with vertical inlet and horizontal outlet, or vice-versa (Fig. 2).

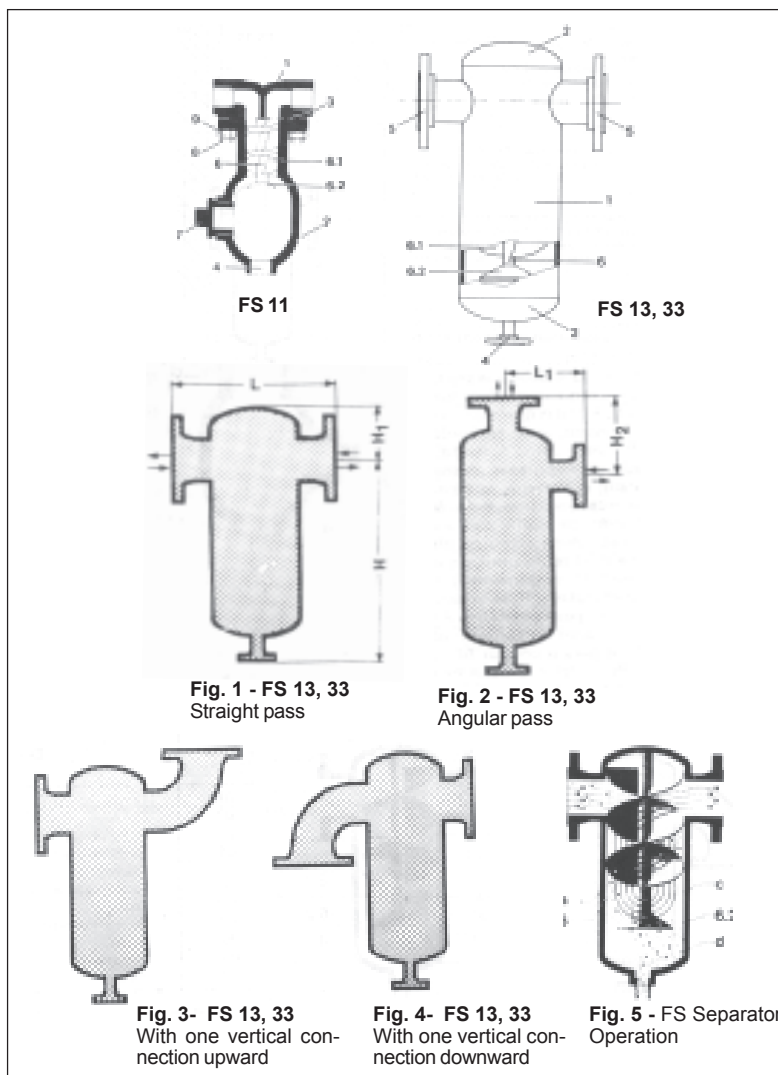

Technical Competence, materials and connections

Model	FS 11	FS 13	FS 33
Nominal pressure	PN 10 - ANSI 125	PN 16 - ANSI 150	PN 40 - ANSI 300
Diameter (inches) Nominal (mm)	15 - 20 1/2" a 3/4"	15 1/2"	- 600 - 24"
Max. operation pressure Function max temp. (°C)	Select in the range diagram		
Materials	Body and cover	ASTM A-126. B	up to ND 6", ASTM A-106 Gr. B ND 8" and over ASTM A-285 C
	Helicoid centrifugator with conic deflector	ASTM A-395	ASTM A-516
	with Flanges	—	Flanged ASTM A-106 Gr. B Threaded sleeve ASTM A-106 ASTM A-105
Connections	ND 15-20. 1/2" - 3/4"	BSP threads or ANSI B 2.1 (NPT)	—
	ND 15-50. 1/2" - 2"	—	Threaded or ANSI B 2.1 (NPT) or beveled ends for butt weld
	ND 15-600. 1/2" - 24"	—	DIN PN 16 flange or DIN PN 16 flange or

Optional

-FS 13 and FS 33 models with one vertical inlet curve turned upwards and horizontal outlet (fig. 3).

-FS 13 and FS 33 models with one vertical inlet curve turned downwards and horizontal outlet (fig. 4).

ASCA TF float steam trap for steam, or TA for compressed air, installed upstream from the drain plug, for automatic drainage.

ASCA FY filter installed between drain nozzle and steam trap.

All the optional items are supplied according to request, with over price.

Dimensions and Weights

Model		FS 13, 33															FS 11						
Size/body (TC)*		20	25	32	40	50	65	80	100	125	150	175	200	250	300	350	400	450	500	600	15	20	
Diameter	Inch	20	25	32	40	50	65	80	100	125	150	175	200	250	300	350	400	450	500	600	15	20	
Nominal	(pol)	3/4	1	1.1/4	1.1/2	2	2.1/2	3	4	5	6	7	8	10	12	14	16	18	20	24	1/2	3/4	
Drain nozzle	(mm)	15	15	15	15	15	25	25	25	25	50	50	50	80	80	80	100	100	100	100	15	15	
Diameter K**	Inch	1/2	1/2	1/2	1/2	1/2	1	1	1	1	2	2	2	3	3	3	4	4	4	4	1/2	1/2	
Dimension In mm	FS 13	L	180	210	220	270	270	320	360	400	440	480	540	640	690	790	840	940	1100	1160	1400	00	10
		L1	90	105	110	135	135	160	180	200	220	240	270	320	345	395	420	470	550	580	700	-	-
		H	226	271	276	346	356	442	512	582	671	777	907	1021	1206	1455	1663	1880	2100	2300	2748	120	-
		H1	64	80	85	95	101	120	137	150	174	188	212	232	269	314	338	375	431	479	547	24	24
	FS 33	H2	125	140	150	175	180	195	210	240	260	290	320	365	405	450	480	535	605	645	790	-	-
		L	180	210	220	270	270	320	360	400	440	480	540	640	690	790	840	940	1100	1160	1400	-	-
		L1	90	105	110	135	135	160	180	200	220	240	270	320	345	395	420	470	550	580	700	-	-
		H	226	271	276	346	356	442	527	583	687	782	912	1038	1224	1466	1682	1904	2124	2324	2784	-	-
Approx. weight	Kg	Since every body size may be provided with several nominal diameters and different standards, the weights are provided after the definition of these items.																				3	3
		lb																					6.6

* The body is sized as a function of the service conditions, in order to optimize the separating effect and is independent of the nominal diameter (ND) of the connections.

** Recommended nominal diameter for drain. The actual nominal diameter of the steam trap shall be sized according to the amount of condensate to be eliminated

Installation

FS Centrifugal Separators shall be installed in horizontal piping, with the drain nozzle (04) turned downwards. The flow direction is indifferent due to the design symmetry.

Automatic drain is recommended, with installation of an ASCA TF float steam trap (for steam), TA (for compressed air), downstream from the drain nozzle (04), as well as an ASCA FY filter between the separator and the steam trap.

Operation

The operation element of the FS separators is the two way helicoid centrifugator (6), were one way receives and the other returns the steam, compressed air or gas. Figure 5 shows how the fluid, still wet and loaded with contaminants, goes down in a helicoid (a) until reaching the conic deflector (6.2), where it is suddenly inverted in a 180° angle (c), going up in a helicoid to the outlet. The centrifugal forces, as well as the effects of the sudden change of direction of this process, effectively separate water droplets and other solid particles, dragged or suspended, with specific weight greater than the fluid (steam, compressed air or gas), bringing them to the collector (d). The sudden inversion of the fluid (c) and the deflector (6.2) hinder the particles from being dragged by the flow again.

The contaminants accumulated in the collector can be drained automatically by a steam trap. (See installation item).

Pressure loss

The pressure loss in the FS separators is equivalent to the head loss observed in a pipe with length corresponding to twice the "L" dimension (see "Dimensions and Weights").

N°	Name	Quantity	
		FS 11	FS 33
1	Body	1	1
2	Head	1	1
3	Body head seal	1	-
4	Drain nozzle	1	1
5	Flange	-	2
6	Helicoid centrifugator	1	1
6.1	Fuses	2	2
6.2	Deflector	1	1
7	Plug	1	-
8	Tie bolt	4	-
9	Nut	4	-

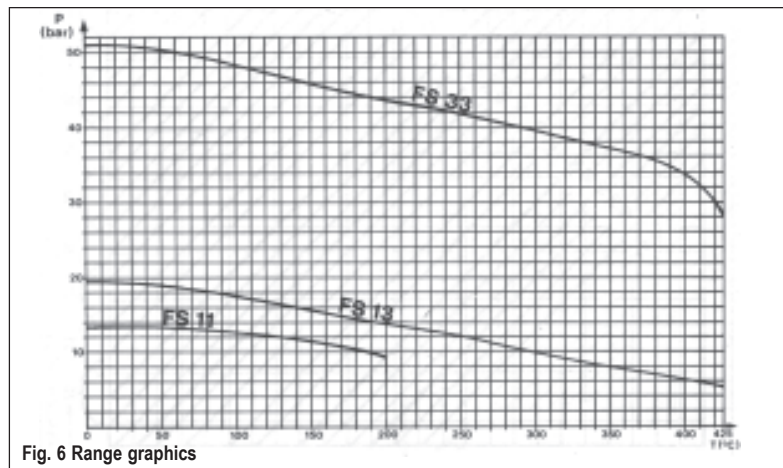

Fig. 6 Range graphics

Sizing of the body size

The diagram "A" (for steam) and "B" (for compressed air) they facilitate the sizing of the body of the separator adapted ace conditions of existent service.

Sizing of the body size

Diagrams "A" (for steam) and "B" (for compressed air) facilitate sizing the body of the separator according to the existing operation conditions

Diagram "A" for steam

This diagram allows the determination of the body size as a function of the pressure, temperature and steam flow.

Example 1

Saturated steam
 Temperature 129,3°C
 At a pressure of 2,7 bar abs
 And steam flow 1.5 ton/h
 From the diagram we find the body size = 175.

Example 2

Superheated steam:
 Temperature 400°C
 At a pressure of 16 bar abs
 And steam flow 30 t/h
 From the diagram we find the body size = 400.

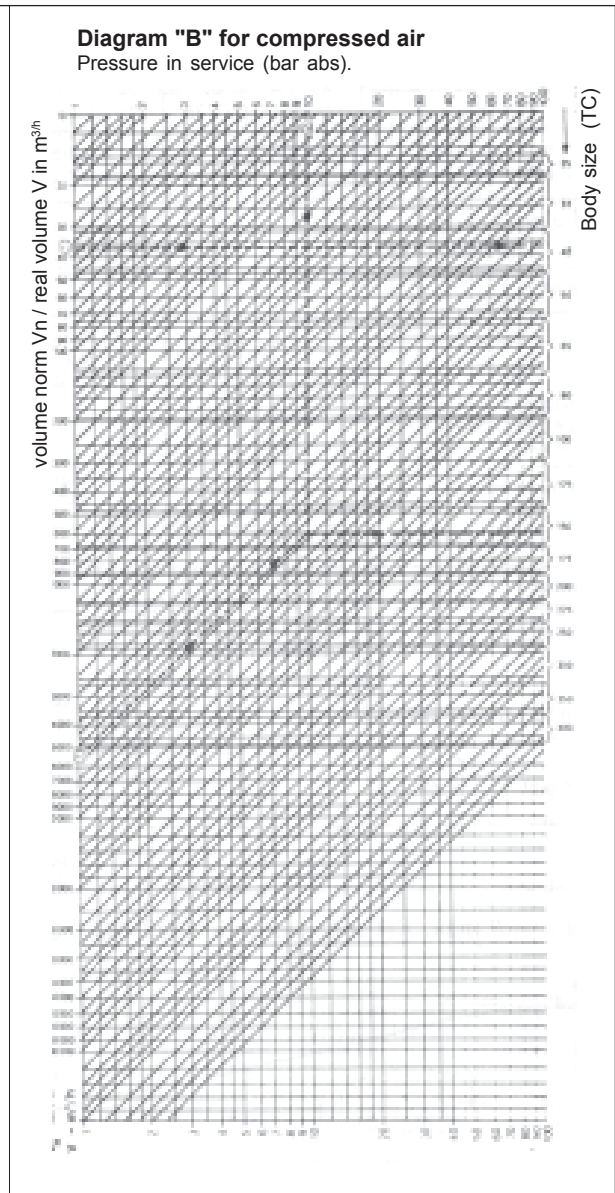
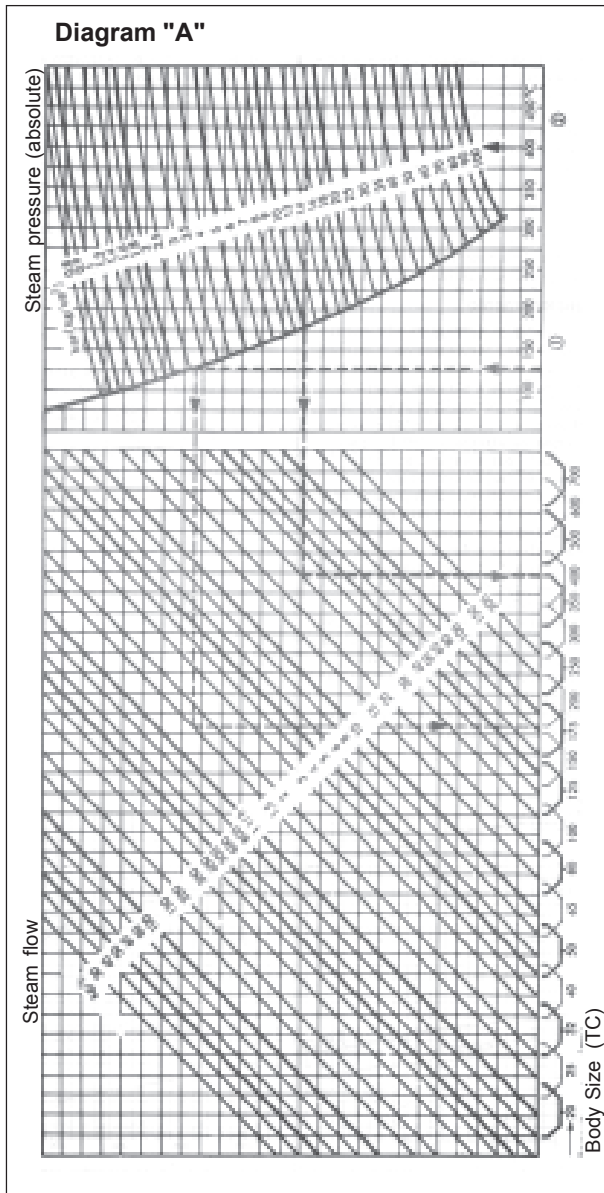

Diagram "B" for compressed air

Diagram "B" for compressed air

This diagram is based upon air at 25°C temperature. Every 10°C added to this temperature, provides an approximate increase of 3% to the air volume.

For example: at a temperature of 45°C, the increase of air volume is approximately 6%.

Example 1

When you know the compressed air volume:
Effective volume V 37 m³/h

Look in the diagram from the left, at the height of the value 37 and draw a horizontal line until the right side, showing the body size.

From the diagram we find:

Body size = 40.

Example 2

When you know the normal air volume, at atmospheric pressure:

Normal volume Vn 5500 m³/h

Operation pressure p 10 bar abs

Look in the diagram from the left, at the height of value 5500 and draw an ascending diagonal line, until the point of intersection with the vertical line corresponding to the 10 bar pressure. From this point, draw a horizontal line until the right side, showing the body size.

From the diagram we find: body size = 150.

Perfect gases

Use the following equation, to convert the normal volume (Vn) of perfect gases into real volume (Vr):

Sizing data

To size the appropriate apparel for your facility, inform the nature of the fluid, pressure and temperature of the installation site of the apparel, as well as maximum flow for continuous operation, or peak flow for intermittent operation. If possible, describe type and application of the consumer to the supplied with the purified fluid.

Inform also the type, standard and nominal diameter (ND) of the connections of the desired body and drain nozzle (K). When this information is not provided, the apparel will be supplied with normal connections.

Standard Specification

Centrifugal Particle Separator

FS model from ASCA

according to PR-11.10.30-I catalog.

- K
- Connections
- According to standard
- Pressure class
- Nominal diameter
- Optional

ASCA EQUIPAMENTOS INDUSTRIAIS LTDA.

R. Fernandes da Cunha, 202- Vigário Geral - Rio de Janeiro - RJ - Brazil
CEP 21241-300 - Tel.: (21) 2472-6900 - Fax (21) 3014-7622
e-mail: office@asca.com.br - homepage: http://www.asca.com.br

SPECIFICATIONS SUBJECT TO CHANGE WITHOUT NOTICE.

Ask for certified print for exact dimensions